

QUADRUCCI FORMING MACHINE

THE MOST INNOVATIVE ON THE MARKET



rev. 001087.2411.73

■ Quadrucci pasta machine

- Shaping unit for quadrucci in a range of sizes, with both smooth and zig-zag edges
- Interchangeable “tailor-made” cutting units for the most traditional shapes
- It can be integrated into existing lines

QUADRUCCI FORMING MACHINE

Shaping unit for quadrucci in a range of sizes, with both smooth and zig-zag edges, 100% stainless steel, accessible for maximum cleanliness. It can be integrated into existing lines and can interface with any PLC or be inverter-run.

Main technical features:

- Shaping unit for quadrucci in a range of sizes, with both smooth and zig-zag edges
- 100% stainless steel, accessible for maximum cleanliness
- It includes interchangeable “tailor-made” cutting units for the most traditional shapes, with two separate motor drives and safety microswitches
- It can be integrated into existing lines and can interface with any PLC or be inverter-run



Quadrucci forming machine - detail



Quadrucci forming machine on short pasta line



Detail of quadrucci

QUADRUCCI FORMING MACHINE

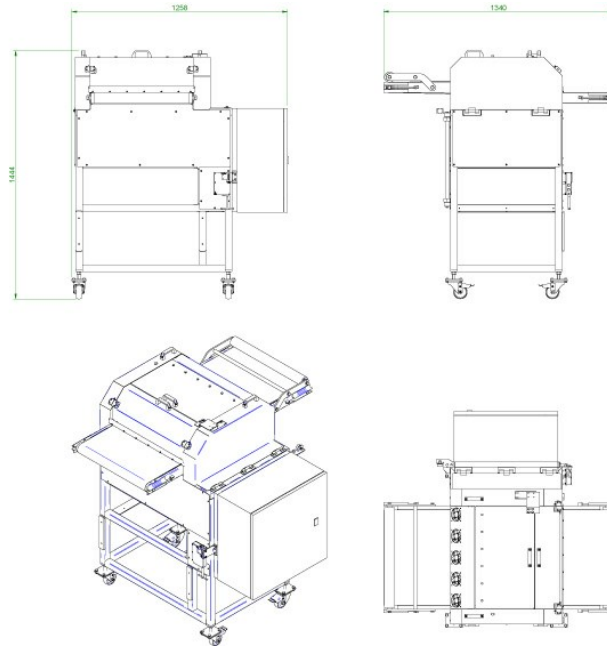

Quadrucci forming machine	
Dimensions	1258x1340x1444
Weight (Kg)	340
Installed power (kW)	0,92
Dry product (Kg/h)	200-250
Cuts	5x5 - 10x10
Edge	smooth/zig-zag

Dimension and technical data are not binding. Storci S.p.A. reserves the right to modify them without notice.



facebook.com/storci.spa



youtube.com/@FAVAspAPastaEquipment



linkedin.com/company/fava-s.p.a.

Fava S.p.A.
Via IV Novembre, 29 - 44042 Cento (FE)
phone: +39 051 6843411
www.favastorci.com - info@fava.it

FAVA
pasta equipment **Storci**