

72.1 TV PRESS

AUTOMATIC TOTAL VACUUM PRESS FOR SHORT-CUT, LONG-CUT



rev. 0013.2411.109

■ 72.1-580/1 TV/L Press for long cut pasta

- Automatic continuous press for short-cut, long-cut pasta
- Production capacity: 150 Kg/h (dry-short) - 120 Kg/h (dry-long)
- Automatic ingredient dosing and premixing with Premix[®] system
- Tempered stainless steel extrusion screw with three-spiral terminal

72.1 TV PRESS

Stainless steel presses for dry and fresh pasta production particularly suitable for small and medium size industrial pasta plants.

By using special dedicated extrusion screws special pasta shapes can also be made.

Main technical features:

- Perfect hydration of ingredients thanks to the patented Premix[®] pre-mixing system
- Volumetric flour dosing and electronic water dosing controlled from a PLC with touch screen: electronic regulation of the flow rates based on the set recipes
- Special dosing systems for egg and other dry and liquid ingredients (optional)
- Vacuum kneading tank with filter pump and vacuum gauge
- Bolt-free kneading paddles for easy cleaning
- Sturdy and long-lasting thrust bearing unit
- High-performance and long-lasting extrusion screws
- Vertical head with manual extraction system
- Short-cut pasta cutting unit with inverter and knives with 1-2-4 blades
- Patented double vertical heads able to avoid the product stagnation (mod.N)
- Direct ventilation for short-cut pasta cutting
- Optional: lasagna



72.1-580/1 TV/L Press for long cut pasta (view from above complete with spreader unit and scraps recovery system)



72.1-580/1 TV/C Press for long-cut pasta (side view)



72.1-580/1 TV/L Press for long cut pasta



Press application for short-cut pasta on ready meals line

72.1 TV PRESS

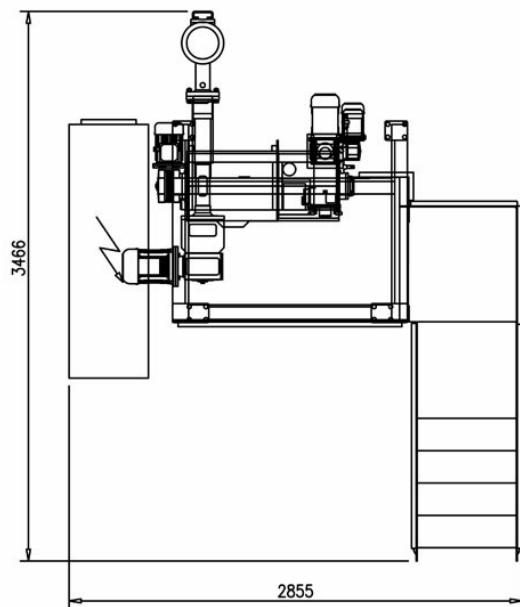
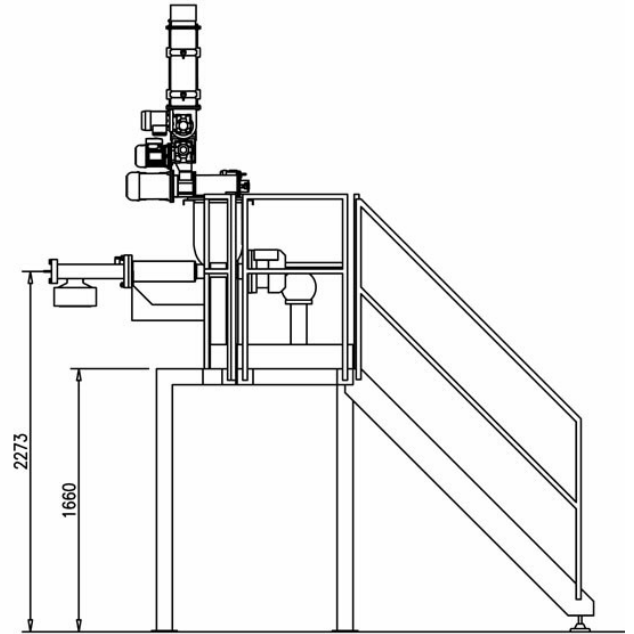
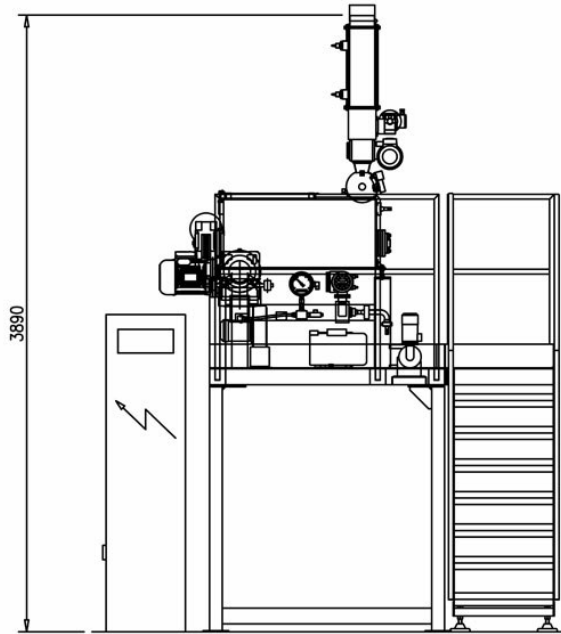

	72.1
Power installed (kW)	26
Compressed air (nl min/bar)	6/8
Weight (short/long) (kg)	1700/2100
Size (LxPxH) (mm)	4200x2400x4100
Mixing basin capacity (l)	100
Dimension drawing (mm)	150/200/220/540
Production (short/dry) (kg/h)	150
Production (long/dry) (kg/h)	120

Dimension and technical data are not binding. Storci S.p.A. reserves the right to modify them without notice.



facebook.com/storci.spa



youtube.com/@FAVAspAPastaEquipment



linkedin.com/company/fava-s.p.a.

Fava S.p.A.
Via IV Novembre, 29 - 44042 Cento (FE)
phone: +39 051 6843411
www.favastorci.com - info@fava.it

FAVA
pasta equipment **Storci**