

# 72.1-220 G-TV PRESS

AUTOMATIC TOTAL VACUUM PRESS



rev. 0017.2411.61

## ■ Press 72.1-220 G-TV

- Continuous automatic press for the production of dry short pasta
- Fresh pasta production 80 – 160 kg/h
- Automatic dosing system
- Under vacuum dough preparation
- Extrusion screw in quenched stainless steel with terminal at three principles
- Die heads Ø 220 mm

# 72.1-220 G-TV PRESS

Press in stainless steel suitable for the production of dry and fresh pasta, particularly right for the automation of laboratory and small firms. It allows automatic production without worker presence.

## Main technical features:

- Volumetric semolina measuring device and peristaltic pump fluid measuring device.
- Vacuum kneading basin with pump, filter and vacuum meter
- Kneading paddles fixed without bolts to make easier the cleaning operations
- Sturdy thrust bearing group studied for long production duration.
- Horizontal die head with metal ring
- Safety manometer with electrical contacts
- Cutting group for the short pasta cut with inverter and set of knives at 1, 2, 4 blades
- Ventilation for short pasta cut

## Optional:

- Raw material premixer system Premix®
- Sistema elettronico di dosaggio ingredienti con PLC con pannello touch screen with touch screen panel



Special unit in steel



Optional: Premix®



Press 72.1-220 G-TV

# 72.1-220 G-TV PRESS

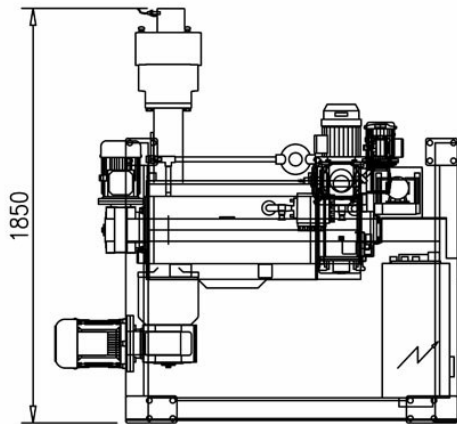
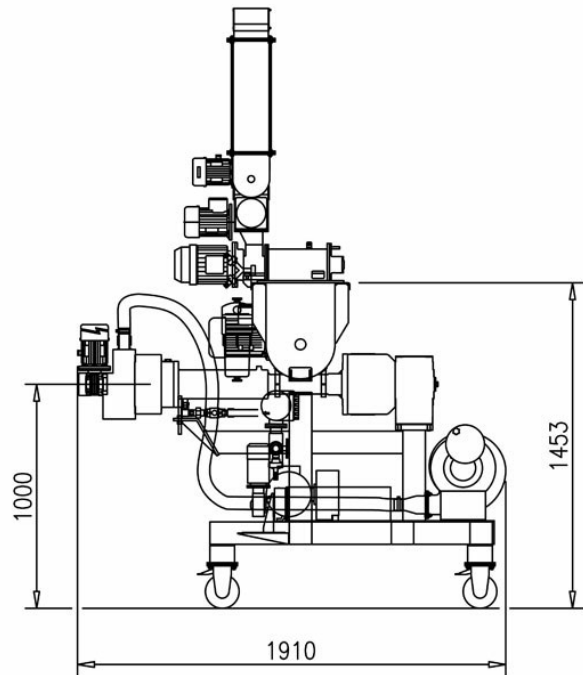
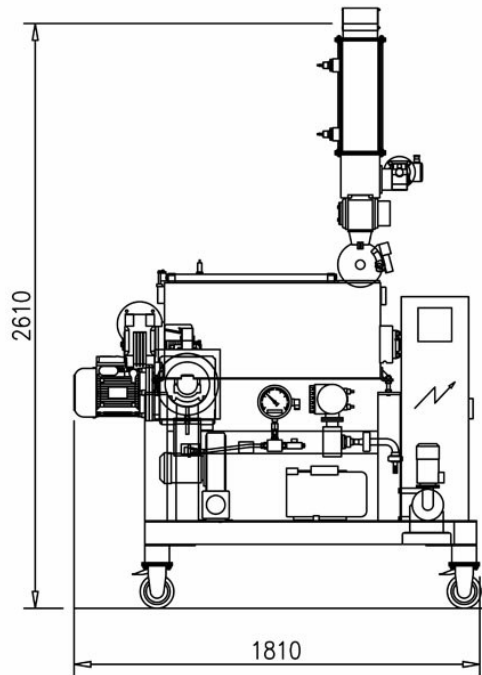

72.1-220 G-TV	
Production (kg/h)	from 80 to 160 Kg/h
Power consumption (kW)	10
Power installed (kW)	11
Weight (kg)	600
Size (mm)	1617x1623x2635
Capacity mixing tank (l)	30
Dimension die heads (mm)	220

Dimension and technical data are not binding. Storci S.p.A. reserves the right to modify them without notice.



[facebook.com/storci.spa](https://facebook.com/storci.spa)



[youtube.com/@FAVAspAPastaEquipment](https://youtube.com/@FAVAspAPastaEquipment)



[linkedin.com/company/fava-s.p.a.](https://linkedin.com/company/fava-s.p.a.)

**Fava S.p.A.**  
Via IV Novembre, 29 - 44042 Cento (FE)  
phone: +39 051 6843411  
[www.favastorci.com](http://www.favastorci.com) - [info@fava.it](mailto:info@fava.it)

**FAVA**  
pasta equipment **Storci**