

REC 1000 C/A/I

SCRAP RECOVERY UNIT



rev. 0019.2411.40

■ Rec 1000 C/A/I

- Unit for recovering fresh pasta scraps: leading ends and tails from production, shape changeover scraps, off-cuts from filled pasta, etc.
- 130-litre feeder tank
- Load cell
- Constant size of the shredded waste and easy re-kneading
- Openable grunder: for a fast and easy cleaning

REC 1000 C/A/I

Unit for recovering fresh pasta scraps: leading ends and tails from production, shape changeover scraps, off-cuts from filled pasta, etc. Allows the user to obtain pasta scraps which can easily be re-kneaded with excellent results.

Main technical features:

- New basket system which forces the scraps through holes (of a set diameter)
- Load hopper for manual or automatic feeding of the fresh product
- Top of the range model incorporating a stainless steel blower (high-thickness steel for acoustic insulation) with quick opening (for easy cleaning) of the entire motor and rotor assembly, set on axial guides
- Load cell for evaluating over time the weight of scraps used on the line
- Feeder belt leading to the grinder below the 130-litre tank
- Processing capacity (indicative): approximately 300-500 kg/h
- Suitable for medium and large pieces
- Ideal for medium and large tank

Optional:

- Piping kit, connections, large-radius bend and decanting centrifugal separator
- Manual or automatic switching valve for multiple feed
- Tank level photocell and relative insufficient product alarm



Uniformly ground product



Detail of openable grinder



■ Rec 1000 C/A/I

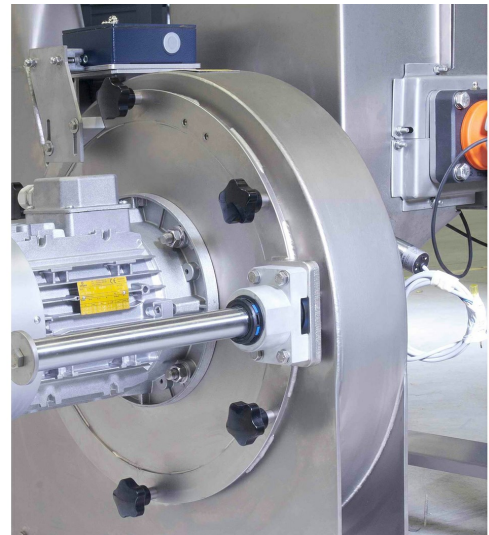

■ Detail of openable grinder

REC 1000 C/A/I

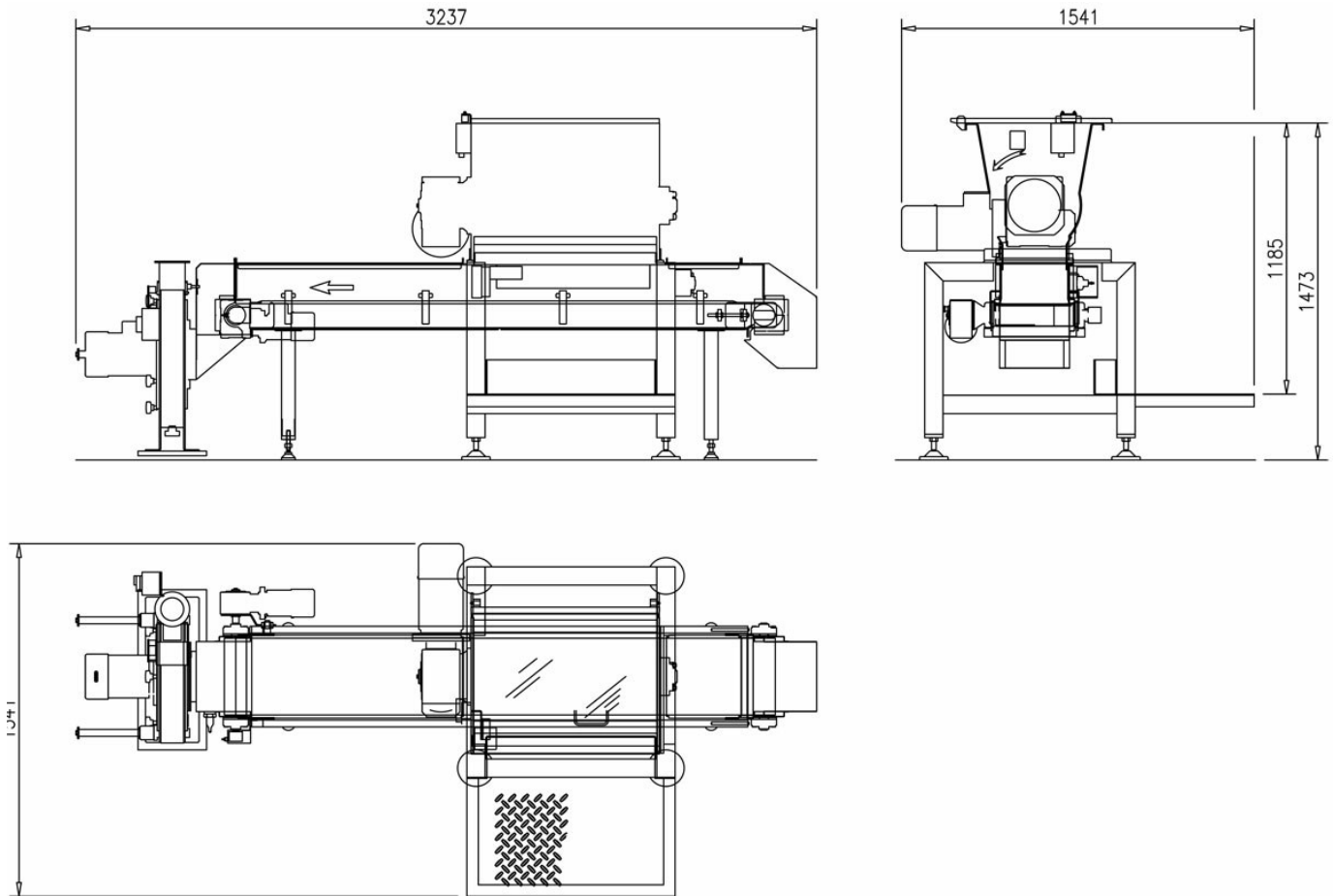

REC 1000 C/A/I				
MODEL	POWER (kW)	LENGTH OF PIPING (mt)	GRINDING CAPACITY (kg/h)	DIMENSIONS (LxPxH)
REC S	10	20	300-500 (*)	3237X1541X1473
REC M	13.5	28	300-500 (*)	3237X1541X1473
REC L	21	40	300-500 (*)	3237X1541X1473

Note: the data provided is purely indicative and not binding as it may be subject to the variability of products and the line in which units are installed.

(*) for products with a dry surface and maximum, evenly distributed, humidity of 30%.



facebook.com/storci.spa



youtube.com/@FAVAspAPastaEquipment



linkedin.com/company/fava-s.p.a.

Fava S.p.A.
Via IV Novembre, 29 - 44042 Cento (FE)
phone: +39 051 6843411
www.favastorci.com - info@fava.it

FAVA
pasta equipment **Storci**