

# ROBO XI / XD

AUTOMATIC TRAY DESTACKERS/STACKERS



rev. 0026.2411.45

■ Robotized line for special nested and short-cut pasta

- Automatic tray destacker - stacker with robotized handling
- Automatic management without the need for operators
- Standard tray size: 1200x600 mm with heights of 50-70 mm
- Can also be adjusted to handle non-standard trays (1200x470 mm)

# ROBO XI / XD

Automatic robots for trays of short-cut pasta, nested pasta and lasagna.

Main technical features:

**Destacker.** At the start of the line the destacker makes it possible to pick up the trays from the trolley and feed them continuously and automatically into the slots on the feeder.

By positioning the trolley full of empty trays in the special safety cage, the robot pick-up head can pick up a constant and adequate number of trays to meet the speed of the trays on the line.

**Stacker.** The trays full of pasta in line outfeed are stacked on the trolley continuously and automatically. Once full, the trolley in the safety cage can be taken to the drying cell by the operator.

Specifically conceived for Storci lines, ideal for all other lines.



*Robo XD tray destacker*



*Robo XI tray stacker*

## Technical characteristics:

- High positioning speed.
- System with dual-axes transfer (or with three axes - optional).
- Pick-up head with two self-centering flaps.
- PLC controlled speed which is adjustable from the operator panel.
- Photoelectric sensors for detecting the height of the stack of trays.
- Can be incorporated into existing lines.

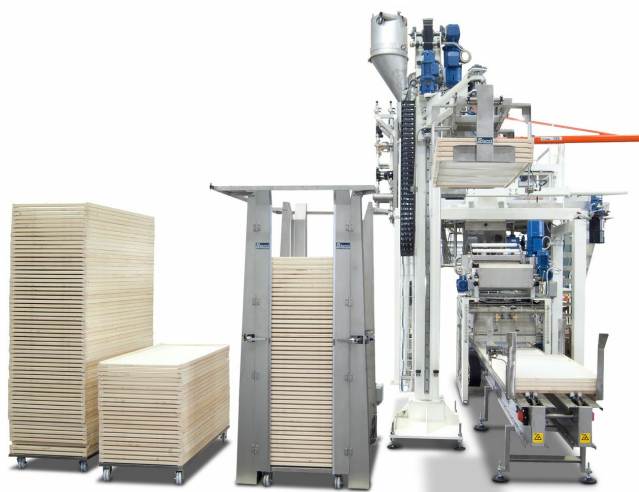

■ Robo XD tray destacker



■ Robo XI tray stacker

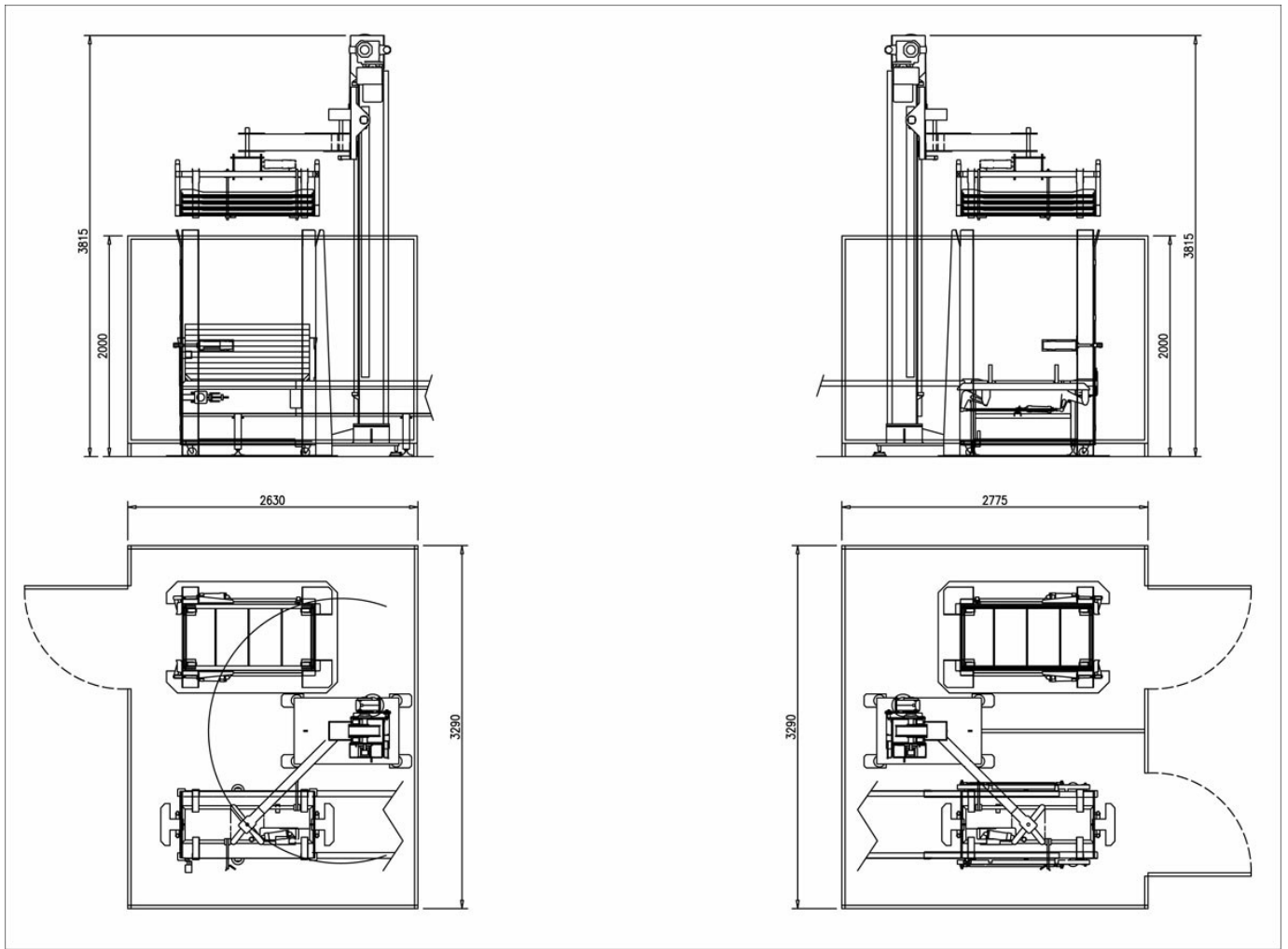

ROBO XI / XD	
<b>Trays dimensions (mm)</b>	1200x600x55
<b>Speed ( trays/min)</b>	4 ( h5 mm )
<b>Power installed (kW)</b>	1.5
<b>Area (m<sup>2</sup>)</b>	8.5
<b>Size LxPxH (mm)</b>	2630x3290x3815

Note: the data provided is purely indicative and not binding as it may be subject to the variability of products and the line in which units are installed.



[facebook.com/storci.spa](https://facebook.com/storci.spa)



[youtube.com/@FAVAspAPastaEquipment](https://youtube.com/@FAVAspAPastaEquipment)



[linkedin.com/company/fava-s.p.a.](https://linkedin.com/company/fava-s.p.a.)

**Fava S.p.A.**  
Via IV Novembre, 29 - 44042 Cento (FE)  
phone: +39 051 6843411  
[www.favastorci.com](http://www.favastorci.com) - [info@fava.it](mailto:info@fava.it)

**FAVA**  
pasta equipment **Storci**