

# BELTMIX

DOUGH PREPARATION UNIT

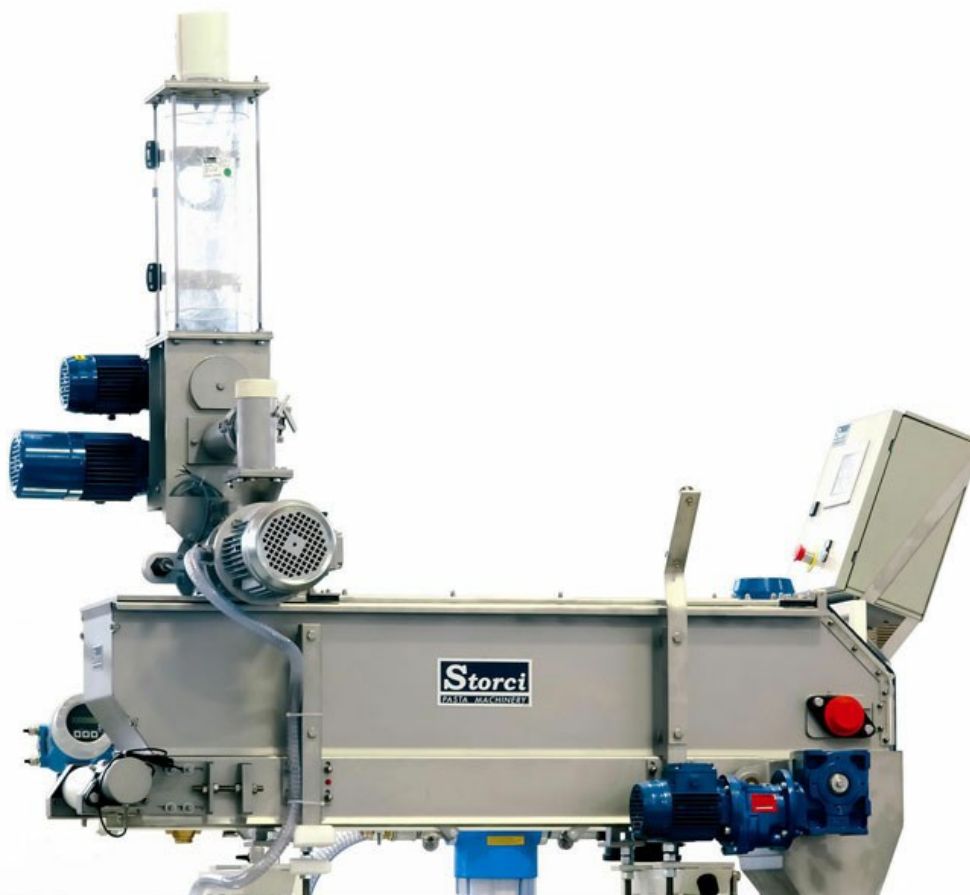

rev. 0033.2411.57

■ Beltmix

- Dough preparation system equipped with accumulation conveyor for the dough rest period
- Patented pre-kneading unit (with automatic ingredient dosing) to guarantee perfect hydration of ingredients
- Top quality pasta with better colour
- Constant dough quality over time: greater manageability of extruders and sheeters and improved shaping machine performance.

# BELTMIX

The **Beltmix** replaces the traditional shaft and blade mixing tank thanks to its pairing with the Premix® and patented slow-moving conveyor belt for the dough rest period.

This mixing system marks a significant technological innovation for dry and fresh pasta and egg or additives (spinach, tomato, etc.) dough.

Since the dough is not subjected to any kind of mechanical action, the Beltmix guarantees that the original properties of the raw materials are kept intact and optimizes the colour of the finished product which, in the absence of oxidation, remains brighter. **Suitable for various sectors: fresh pasta, fresh filled pasta, sheet pasta, dried pasta, gluten-free pasta and gnocchi.** The PLC allows the user to store a high number of recipes which can be easily modified. Coloured doughs: quick recipe changeover times thanks to the self-cleaning unit.



*Dough stabilization belt*

## Main technical features:

- Perfect hydration of ingredients thanks to the patented Premix system®
- Doughs maintain their characteristics over time: The other units can be adjusted more efficiently
- Volumetric flour dosing and electronic water dosing
- Additional dosing for liquid eggs and other liquid ingredients.
- PLC for the electronic management of the unit and recipes storage

## Advantages:

- Top quality doughs with a better colour
- Better production management with more efficient product changeover: 5 minutes even for coloured doughs
- It guarantees that the original properties of the raw materials are kept intact and optimizes the colour of the finished product
- Low energy consumption: savings of up to 21,000 Euros a year
- Maximum accessibility for easy cleaning: ten times quicker



*Beltmix application on press*



■ Dough on belt



■ Beltmix

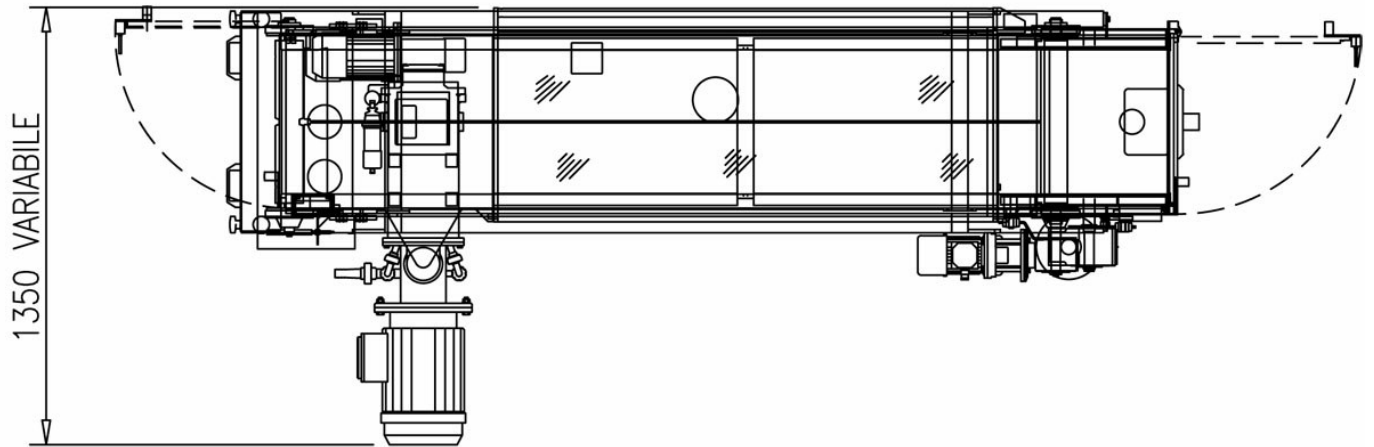
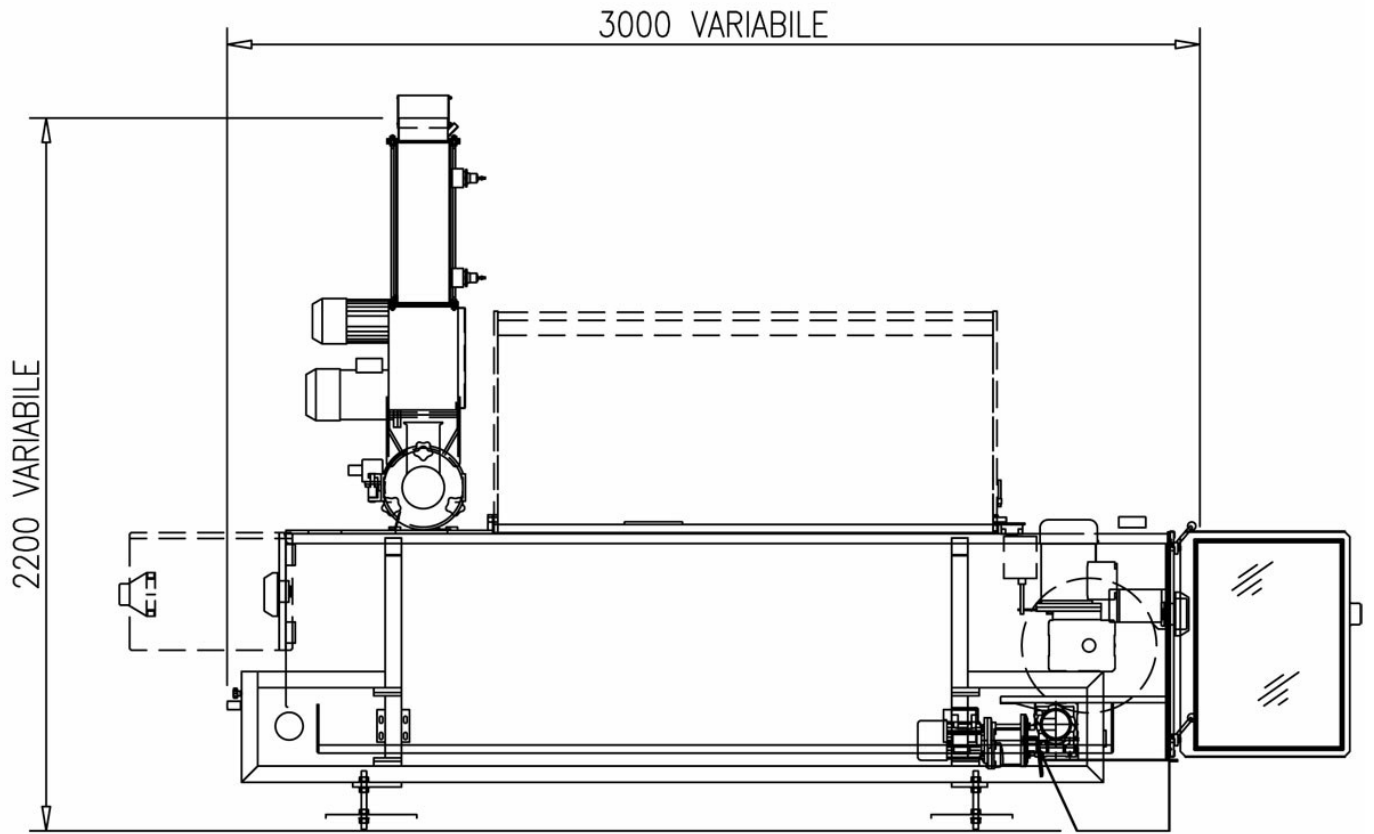



[facebook.com/storci.spa](https://facebook.com/storci.spa)



[youtube.com/@FAVAspAPastaEquipment](https://youtube.com/@FAVAspAPastaEquipment)



[linkedin.com/company/fava-s.p.a.](https://linkedin.com/company/fava-s.p.a.)

Fava S.p.A.  
Via IV Novembre, 29 - 44042 Cento (FE)  
phone: +39 051 6843411  
[www.favastorci.com](http://www.favastorci.com) - [info@fava.it](mailto:info@fava.it)

**FAVA**  
pasta equipment **Storci**