

VSF TV/MIX DOUGH SHEETER

AUTOMATIC VACUUM DOUGH SHEETER



rev. 005.2411.43

■ VSF TV/MIX

- The “VSF TV/MIX” vacuum dough sheeter represents a revolutionary innovation
- Fresh production capacity: approximately 250-500 kg/h
- Equipped with a dough preparation unit complete with automatic dosing and Premix® to make this machine fully autonomous
- Two kneading rollers and one pair of laminating rollers with separate motor drive
- Totally reliable, maximum pasta quality and extremely easy to clean

VSF TV/MIX DOUGH SHEETER

Automatic absolute vacuum dough sheeter in stainless steel for producing pasta sheets. Automatic production which does not require the fixed presence of an operator.

Equipped with a Premix[®] dough preparation unit complete with automatic dosing of ingredients. Laminated sheet production for filled pasta.

The VSF TV/MIX dough sheeter is designed to produce pasta sheets in the total absence of air to obtain (based on the use of the same raw materials) a product which is:

- A more intense shade of yellow
- More elastic
- More compact
- Better at withstanding cooking.

Main technical features:

- Ideal for producing filled pasta and pasta sheets of medium humidity.
- Volumetric flour doser
- Electronically controlled dosing system for liquid ingredients.
- Vacuum kneading tank with filter pump and vacuum gauge.
- Bolt-free kneading paddles for easy cleaning
- All parts in contact with the dough made from stainless steel and non-toxic polymer.
- Pasta sheet conveyor belt.
- PLC with touch screen.



VSF TV/MIX with automatic mixing system



Kneading and calibration system



VSF TV/MIX with automatic mixing system

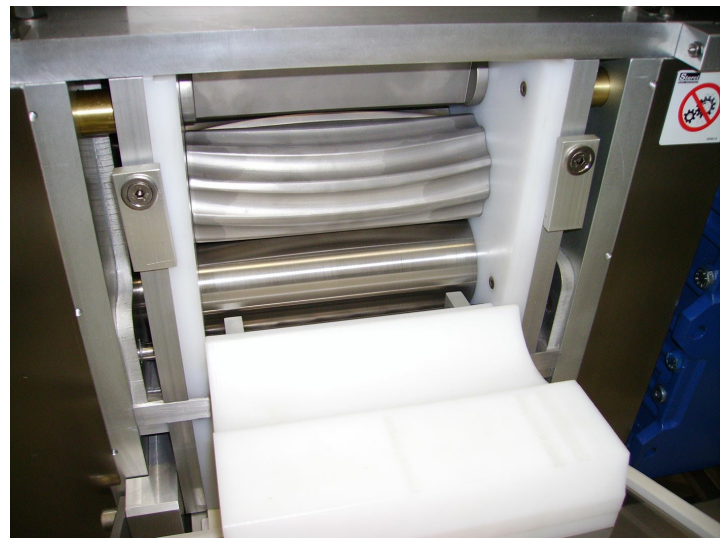

Kneading and calibration system

VSF TV/MIX DOUGH SHEETER

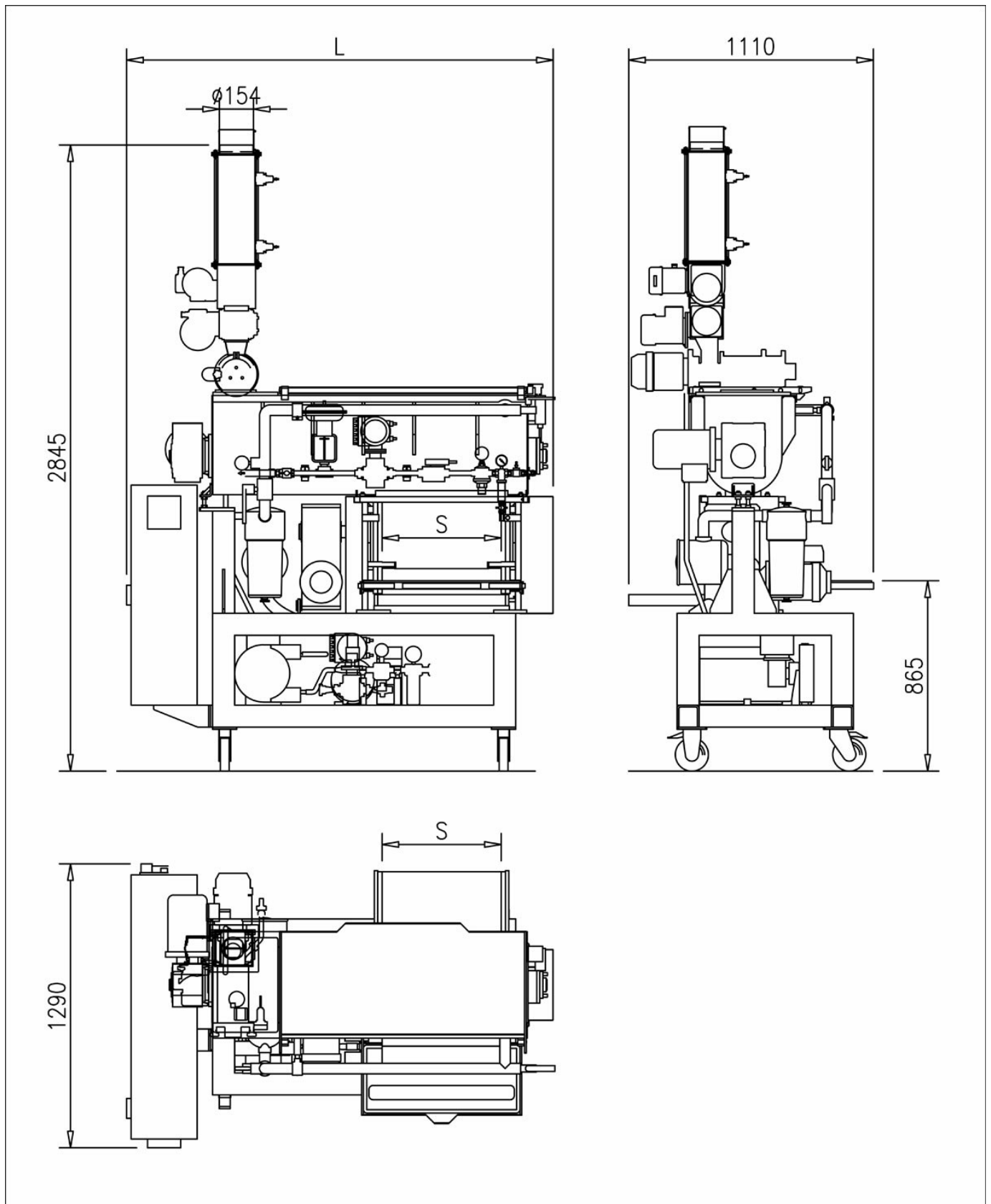

	VSF TV/MIX 250	VSF TV/MIX 540
Sheet width S (mm)	250	540
Fresh production(kg/h)	250	500
Installed power(kW)	8	13
Weight (kg)	800	1000
Dimensions LxPxH (mm)	164x129x284	193x129x284

Dimension and technical data are not binding. Storci S.p.A. reserves the right to modify them without notice.



facebook.com/storci.spa



youtube.com/@FAVAspAPastaEquipment



linkedin.com/company/fava-s.p.a.

Fava S.p.A.
Via IV Novembre, 29 - 44042 Cento (FE)
phone: +39 051 6843411
www.favastorci.com - info@fava.it

FAVA
pasta equipment **Storci**