

# TROLLEY PREMIX®

DOUGH PREPARATION UNIT

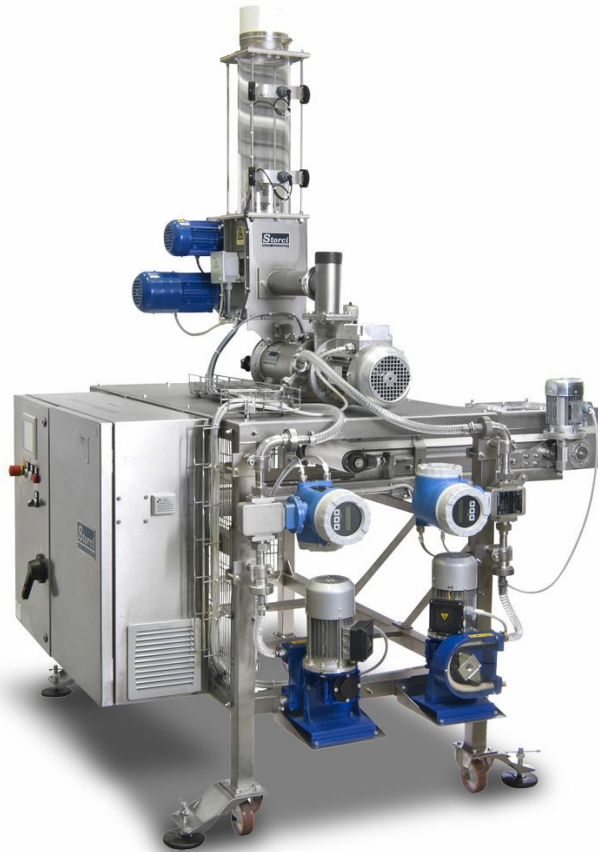

rev. 007.2411.123

## ■ Trolley Premix®

- Centralized dough preparation system (with automatic ingredients dosing) for feeding different processing units
- Patented premix unit to guarantee perfect hydration of ingredients
- Constant dough quality over time: greater manageability of extruders and sheeters and improved shaping machine performance
- Less personnel required for dough preparation with subsequent greater efficiency in other more complex departments

# TROLLEY PREMIX®

Stainless steel dough preparation system equipped with automatic dosing units for dry and liquid ingredients. Suitable for various sectors: fresh pasta, fresh filled pasta, sheet pasta, dried pasta, gluten-free pasta and gnocchi. The PLC allows the user to store a high number of recipes which can be easily modified.

Colored doughs: quick recipe changeover times thanks to the self-cleaning unit.

## Main technical features:

- Can be moved so that it is near the processing machines (presses, sheeters, shaping machines for regional pasta shapes, etc.)
- Perfect hydration of ingredients thanks to the patented Premix® system
- Doughs maintain their characteristics over time. The other units can be adjusted more efficiently
- Volumetric flour dosing and electronic water dosing
- Additional dosing for liquid eggs and other liquid ingredients

## Advantages:

- Elimination of the kneading tanks with manual dosing
- Smaller dimensions
- Large range of production capacities
- Low energy consumption
- Maximum accessibility for easy cleaning



Trolley-mounted tank with dough



Trolley Premix®



Trolley Premix®



Trolley-mounted tank with dough

# TROLLEY PREMIX®

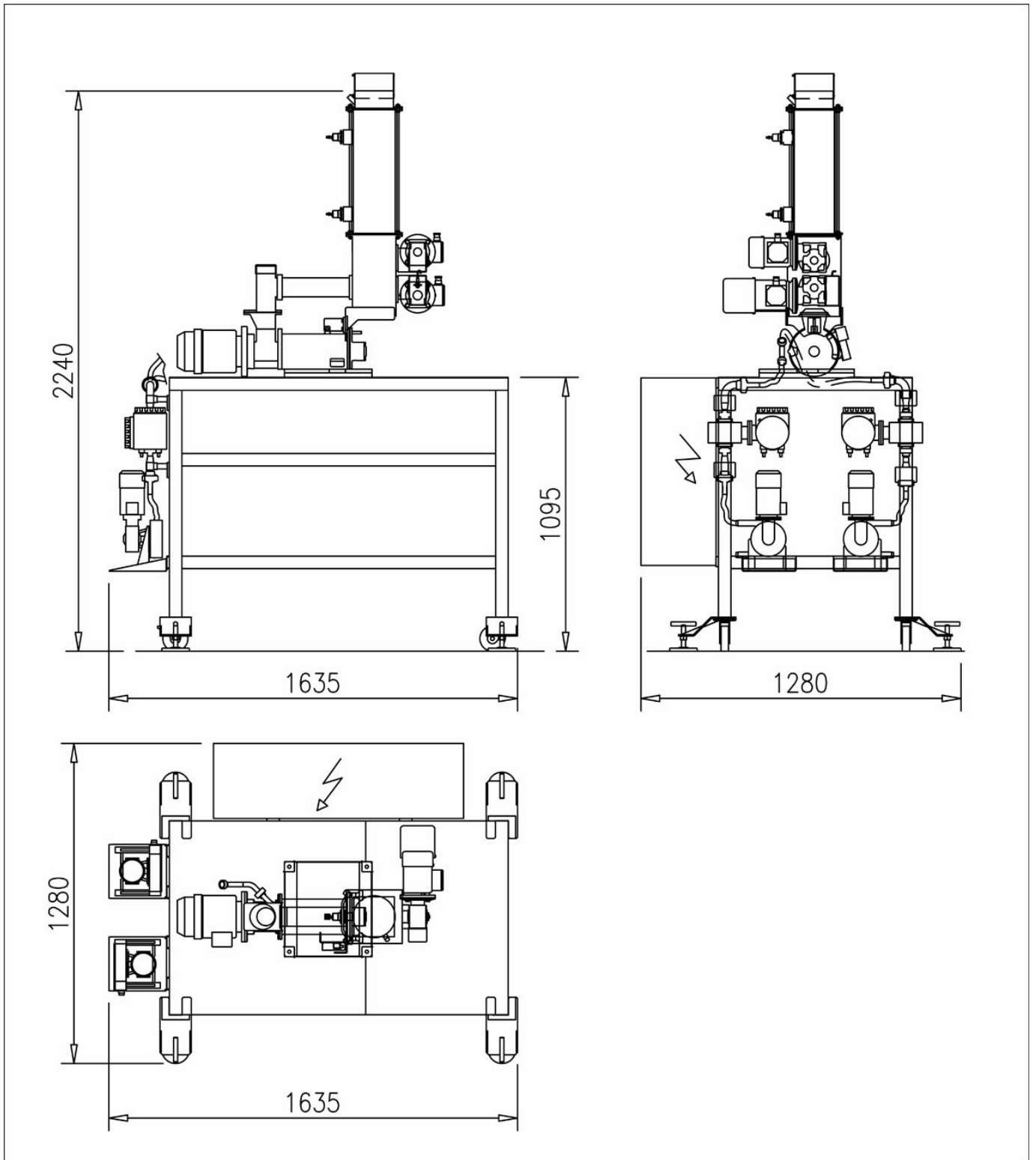



[facebook.com/storci.spa](https://facebook.com/storci.spa)



[youtube.com/@FAVAspAPastaEquipment](https://youtube.com/@FAVAspAPastaEquipment)



[linkedin.com/company/fava-s.p.a.](https://linkedin.com/company/fava-s.p.a.)

**Fava S.p.A.**  
Via IV Novembre, 29 - 44042 Cento (FE)  
phone: +39 051 6843411  
[www.favastorci.com](http://www.favastorci.com) - [info@fava.it](mailto:info@fava.it)

**FAVA**  
pasta equipment **Storci**